

LM78XX Series Voltage Regulators

General Description

The LM78XX series of three terminal regulators is available with several fixed output voltages making them useful in a wide range of applications. One of these is local on card regulation, eliminating the distribution problems associated with single point regulation. The voltages available allow these regulators to be used in logic systems, instrumentation, HiFi, and other solid state electronic equipment. Although designed primarily as fixed voltage regulators these devices can be used with external components to obtain adjustable voltages and currents.

The LM78XX series is available in an aluminum TO-3 package which will allow over 1.0A load current if adequate heat sinking is provided. Current limiting is included to limit the peak output current to a safe value. Safe area protection for the output transistor is provided to limit internal power dissipation. If internal power dissipation becomes too high for the heat sinking provided, the thermal shutdown circuit takes over preventing the IC from overheating.

Considerable effort was expended to make the LM78XX series of regulators easy to use and minimize the number of external components. It is not necessary to bypass the out-

put, although this does improve transient response. Input bypassing is needed only if the regulator is located far from the filter capacitor of the power supply.

For output voltage other than 5V, 12V and 15V the LM117 series provides an output voltage range from 1.2V to 57V.

Features

- Output current in excess of 1A
- Internal thermal overload protection
- No external components required
- Output transistor safe area protection
- Internal short circuit current limit
- Available in the aluminum TO-3 package

Voltage Range

LM7805C	5V
LM7812C	12V
LM7815C	15V

Connection Diagrams

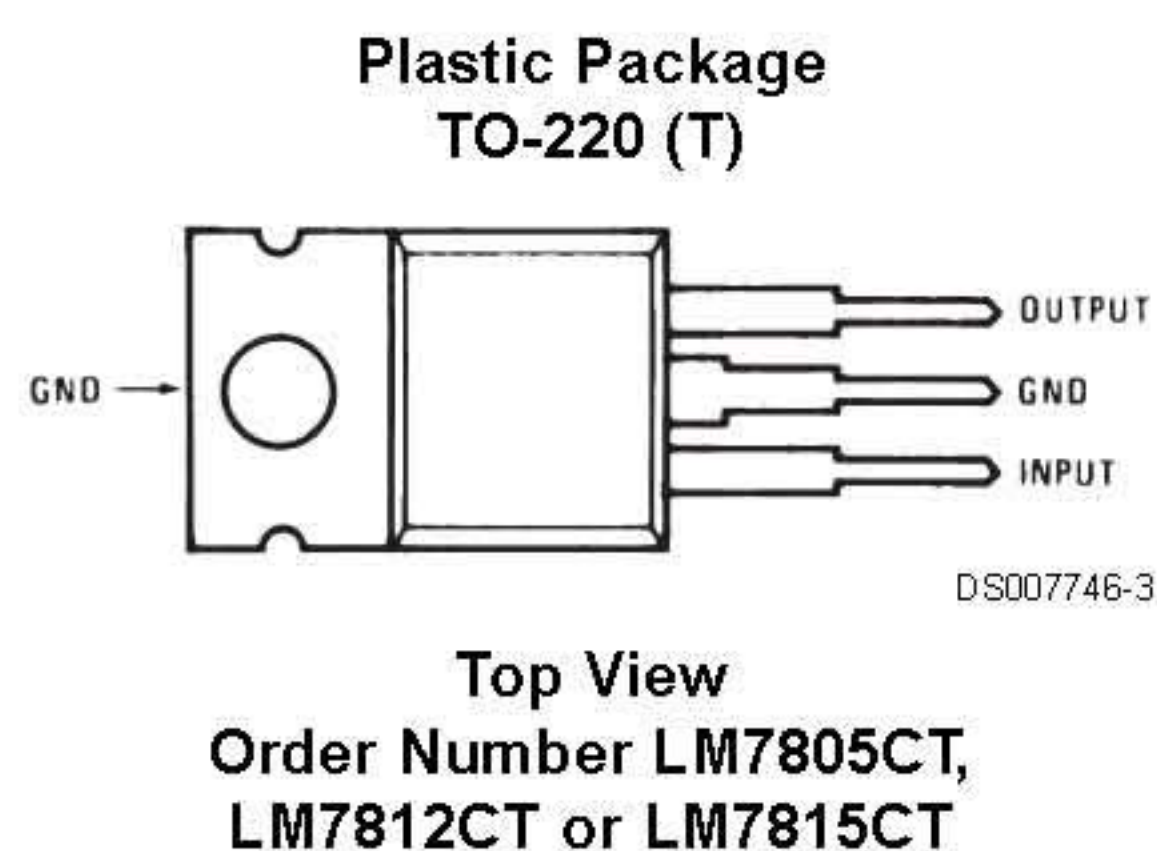
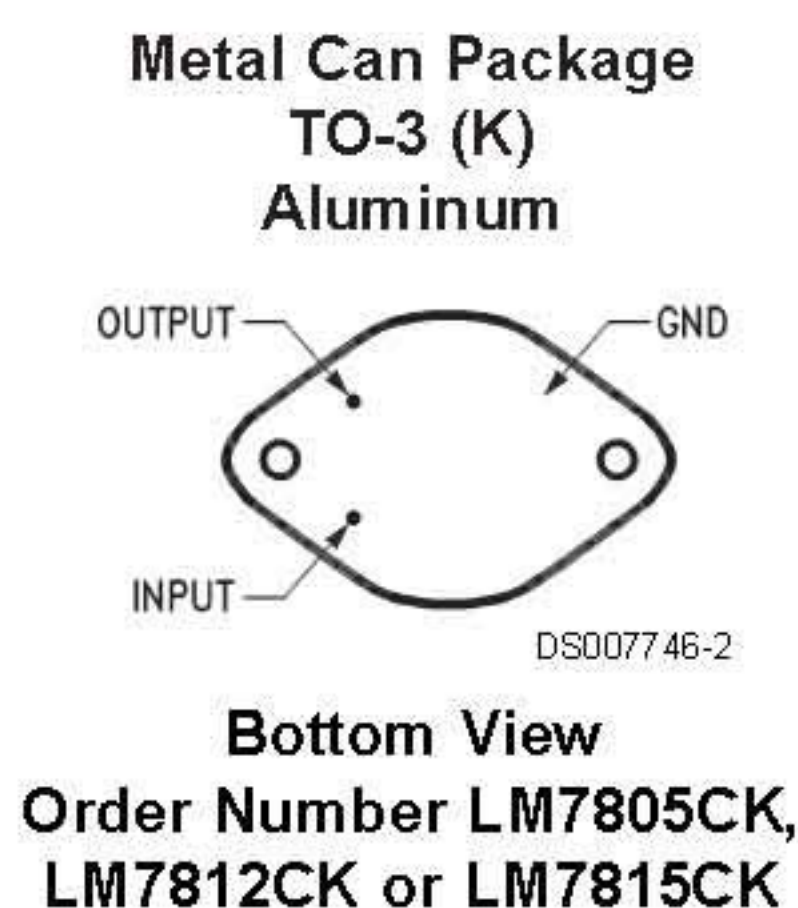

Schematic

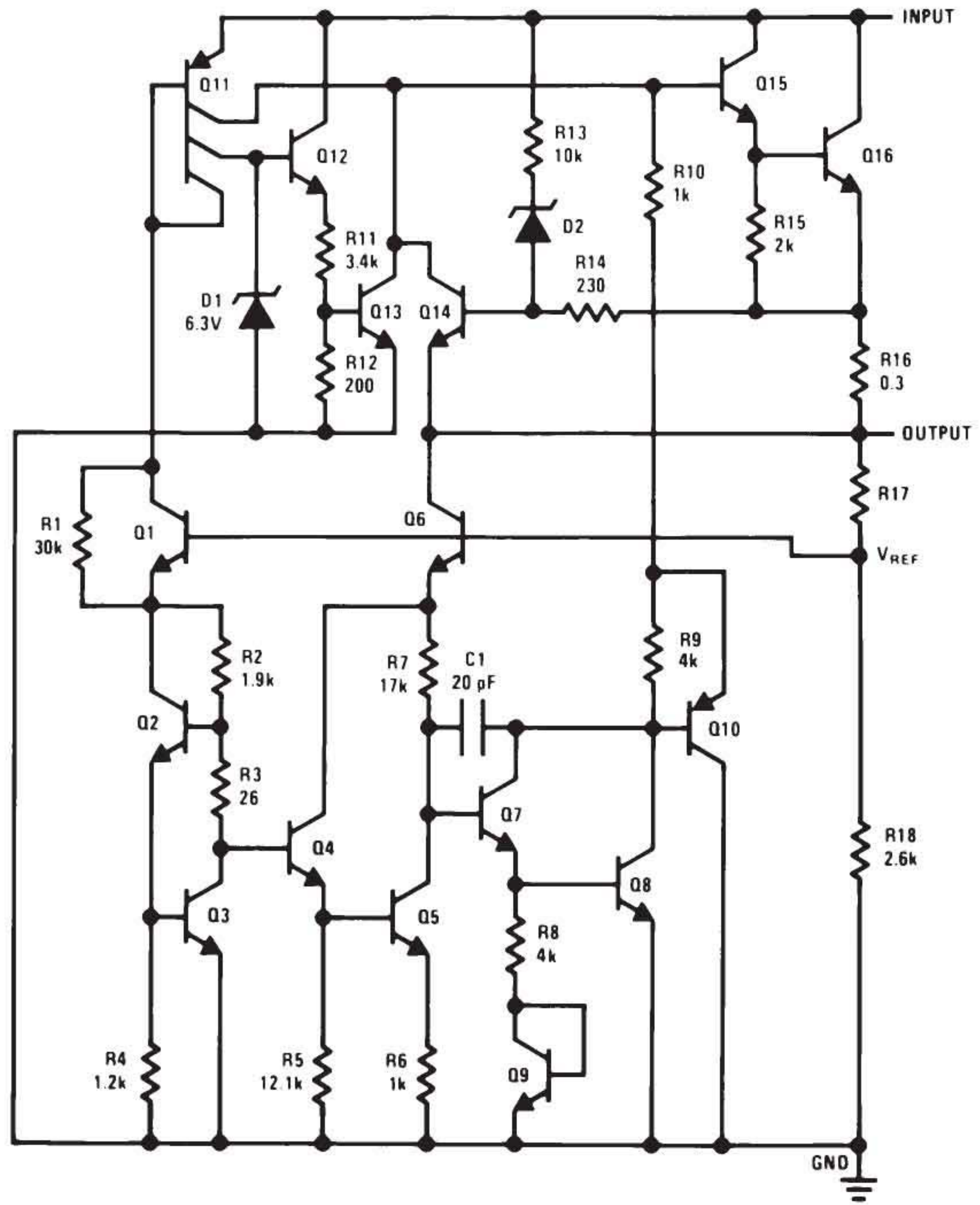

DS007746-1

Absolute Maximum Ratings (Note 3)

If Military/Aerospace specified devices are required, please contact the National Semiconductor Sales Office/Distributors for availability and specifications.

Input Voltage ($V_O = 5V, 12V$ and $15V$)	35V
Internal Power Dissipation (Note 1)	Internally Limited
Operating Temperature Range (T_A)	0°C to $+70^\circ\text{C}$

Maximum Junction Temperature (K Package)	150°C
(T Package)	150°C
Storage Temperature Range	-65°C to $+150^\circ\text{C}$
Lead Temperature (Soldering, 10 sec.)	
TO-3 Package K	300°C
TO-220 Package T	230°C

Electrical Characteristics LM78XXC (Note 2)

$0^\circ\text{C} \leq T_J \leq 125^\circ\text{C}$ unless otherwise noted.

Output Voltage		5V			12V			15V			Units			
Input Voltage (unless otherwise noted)		10V			19V			23V						
Symbol	Parameter	Conditions		Min	Typ	Max	Min	Typ	Max	Min	Typ	Max		
V_O	Output Voltage	$T_J = 25^\circ\text{C}, 5\text{ mA} \leq I_O \leq 1\text{ A}$		4.8	5	5.2	11.5	12	12.5	14.4	15	15.6	V	
		$P_D \leq 15\text{ W}, 5\text{ mA} \leq I_O \leq 1\text{ A}$		4.75		5.25	11.4		12.6	14.25		15.75		V
		$V_{\text{MIN}} \leq V_{\text{IN}} \leq V_{\text{MAX}}$		(7.5 $\leq V_{\text{IN}} \leq 20$)		(14.5 $\leq V_{\text{IN}} \leq 27$)		(17.5 $\leq V_{\text{IN}} \leq 30$)					V	
ΔV_O	Line Regulation	$I_O = 500\text{ mA}$	$T_J = 25^\circ\text{C}$	3		50	4		120	4		150	mV	
			ΔV_{IN}	(7 $\leq V_{\text{IN}} \leq 25$)		(14.5 $\leq V_{\text{IN}} \leq 30$)		(17.5 $\leq V_{\text{IN}} \leq 30$)					V	
		$0^\circ\text{C} \leq T_J \leq +125^\circ\text{C}$			50			120			150			mV
		ΔV_{IN}	(8 $\leq V_{\text{IN}} \leq 20$)		(15 $\leq V_{\text{IN}} \leq 27$)		(18.5 $\leq V_{\text{IN}} \leq 30$)					V		
ΔV_O	Load Regulation	$T_J = 25^\circ\text{C}$	$5\text{ mA} \leq I_O \leq 1.5\text{ A}$	10		50	12		120	12		150	mV	
			$250\text{ mA} \leq I_O \leq 750\text{ mA}$			25			60			75	mV	
		$5\text{ mA} \leq I_O \leq 1\text{ A}, 0^\circ\text{C} \leq T_J \leq +125^\circ\text{C}$			50			120			150			mV
		I_Q	Quiescent Current	$I_O \leq 1\text{ A}$	$T_J = 25^\circ\text{C}$	8			8			8		
$0^\circ\text{C} \leq T_J \leq +125^\circ\text{C}$	8.5					8.5			8.5			mA		
ΔI_Q	Quiescent Current Change	$5\text{ mA} \leq I_O \leq 1\text{ A}$		0.5			0.5			0.5			mA	
		$T_J = 25^\circ\text{C}, I_O \leq 1\text{ A}$		1.0			1.0			1.0			mA	
		$V_{\text{MIN}} \leq V_{\text{IN}} \leq V_{\text{MAX}}$		(7.5 $\leq V_{\text{IN}} \leq 20$)		(14.8 $\leq V_{\text{IN}} \leq 27$)		(17.9 $\leq V_{\text{IN}} \leq 30$)					V	
V_N	Output Noise Voltage	$T_A = 25^\circ\text{C}, 10\text{ Hz} \leq f \leq 100\text{ kHz}$		40			75			90			μV	
		$\frac{\Delta V_{\text{IN}}}{\Delta V_{\text{OUT}}}$	Ripple Rejection	$I_O \leq 1\text{ A}, T_J = 25^\circ\text{C}$	62		80	55		72	54		70	dB
				$f = 120\text{ Hz}$	62			55			54			dB
$V_{\text{MIN}} \leq V_{\text{IN}} \leq V_{\text{MAX}}$		(8 $\leq V_{\text{IN}} \leq 18$)		(15 $\leq V_{\text{IN}} \leq 25$)		(18.5 $\leq V_{\text{IN}} \leq 28.5$)					V			
R_O	Dropout Voltage Output Resistance	$T_J = 25^\circ\text{C}, I_{\text{OUT}} = 1\text{ A}$		2.0			2.0			2.0			V	
		$f = 1\text{ kHz}$		8			18			19			$\text{m}\Omega$	

ARTSCHIP

LM78XX

Electrical Characteristics LM78XXC (Note 2) (Continued)

$0^{\circ}\text{C} \leq T_j \leq 125^{\circ}\text{C}$ unless otherwise noted.

Output Voltage			5V			12V			15V			Units
Input Voltage (unless otherwise noted)			10V			19V			23V			
Symbol	Parameter	Conditions	Min	Typ	Max	Min	Typ	Max	Min	Typ	Max	
	Short-Circuit Current	$T_j = 25^{\circ}\text{C}$		2.1			1.5			1.2		A
	Peak Output Current	$T_j = 25^{\circ}\text{C}$		2.4			2.4			2.4		A
	Average TC of V_{OUT}	$0^{\circ}\text{C} \leq T_j \leq +125^{\circ}\text{C}$, $I_o = 5\text{ mA}$		0.6			1.5			1.8		$\text{mV}/^{\circ}\text{C}$
V_{IN}	Input Voltage Required to Maintain Line Regulation	$T_j = 25^{\circ}\text{C}$, $I_o \leq 1\text{ A}$		7.5			14.6			17.7		V

Note 1: Thermal resistance of the TO-3 package (K, KC) is typically $4^{\circ}\text{C}/\text{W}$ junction to case and $35^{\circ}\text{C}/\text{W}$ case to ambient. Thermal resistance of the TO-220 package (T) is typically $4^{\circ}\text{C}/\text{W}$ junction to case and $50^{\circ}\text{C}/\text{W}$ case to ambient.

Note 2: All characteristics are measured with capacitor across the input of $0.22\ \mu\text{F}$, and a capacitor across the output of $0.1\ \mu\text{F}$. All characteristics except noise voltage and ripple rejection ratio are measured using pulse techniques ($t_w \leq 10\ \text{ms}$, duty cycle $\leq 5\%$). Output voltage changes due to changes in internal temperature must be taken into account separately.

Note 3: Absolute Maximum Ratings indicate limits beyond which damage to the device may occur. For guaranteed specifications and the test conditions, see Electrical Characteristics.

Typical Performance Characteristics

Maximum Average Power Dissipation

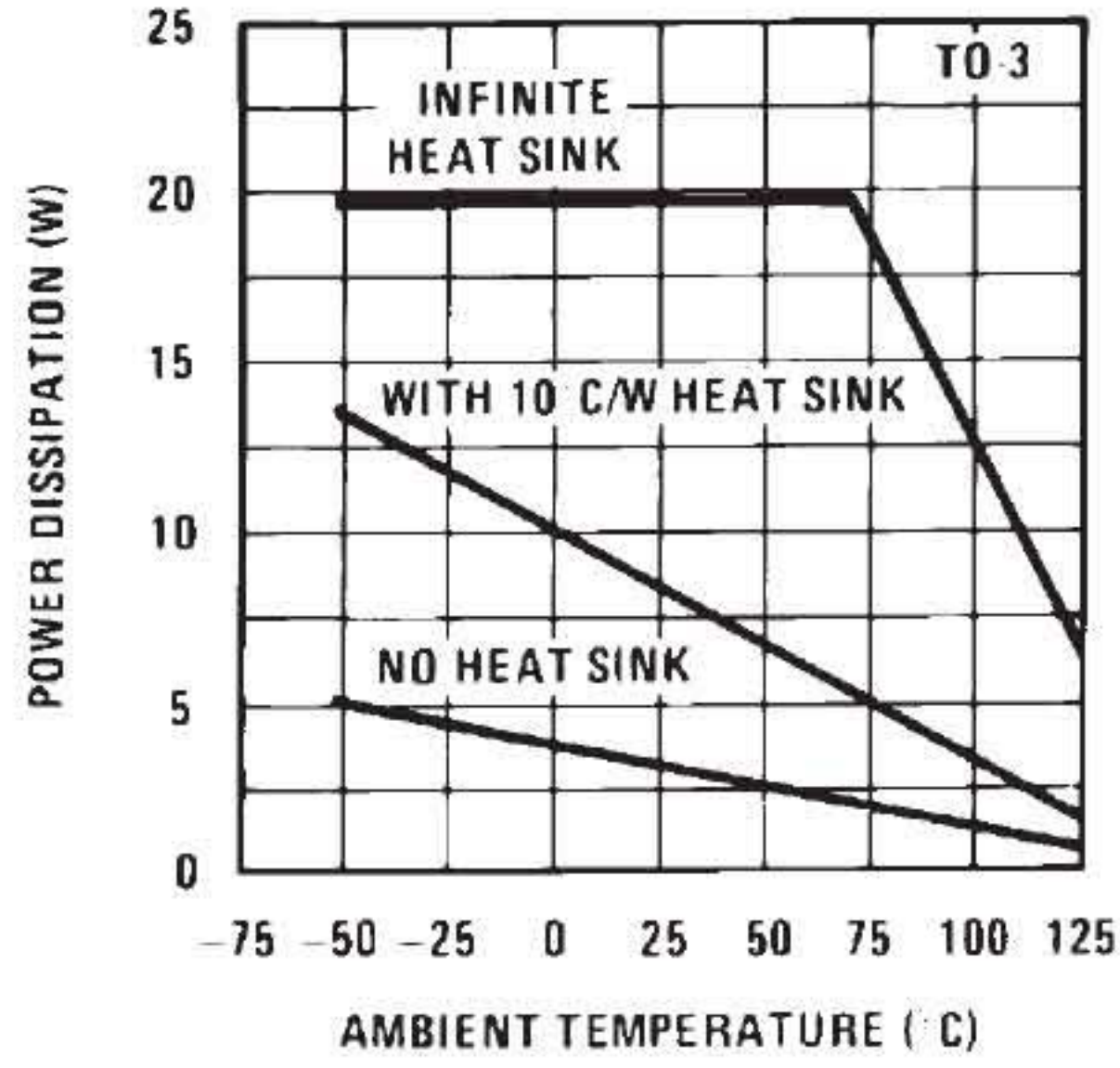

DS007746-5

Maximum Average Power Dissipation

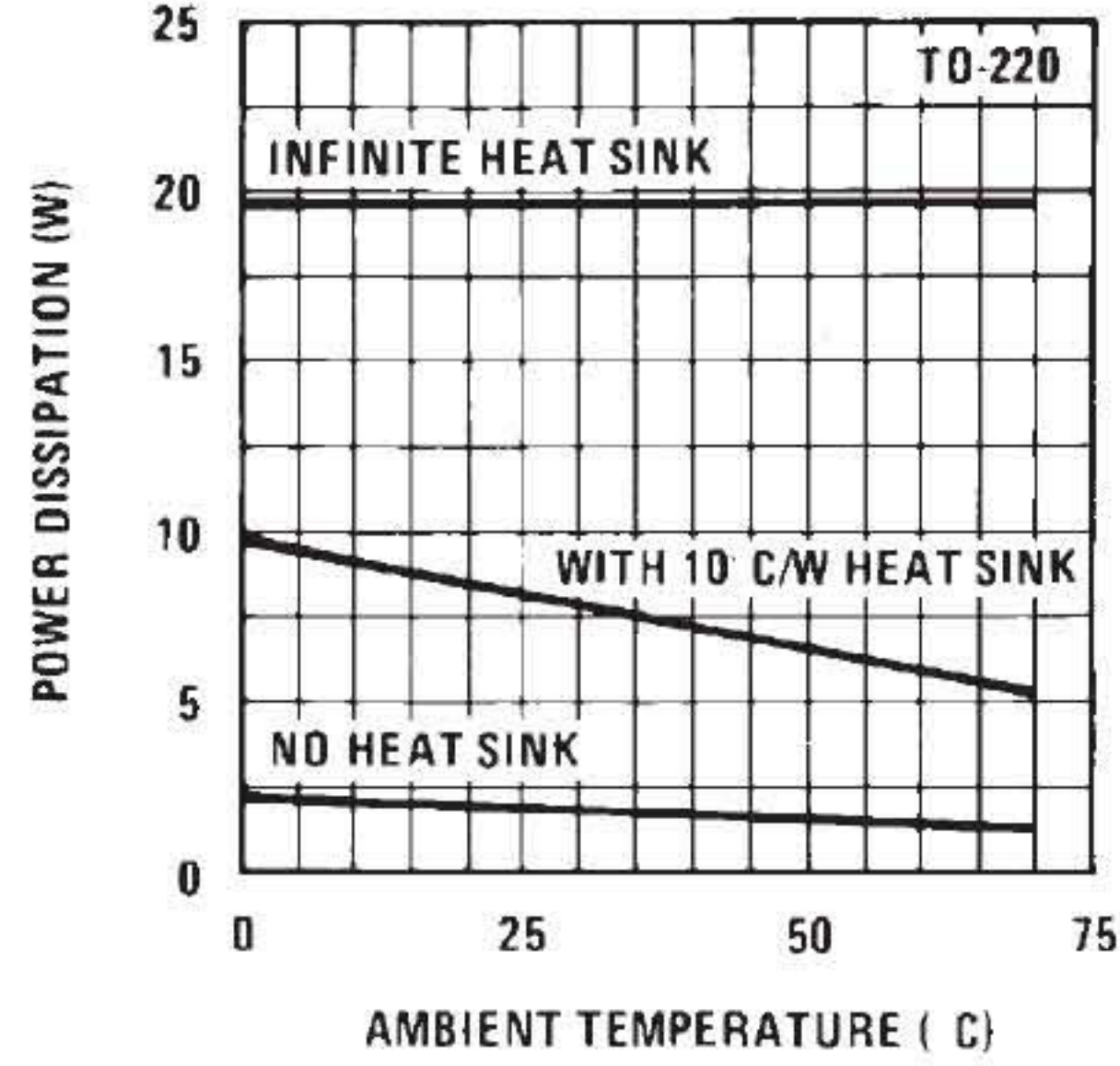

DS007746-6

Peak Output Current

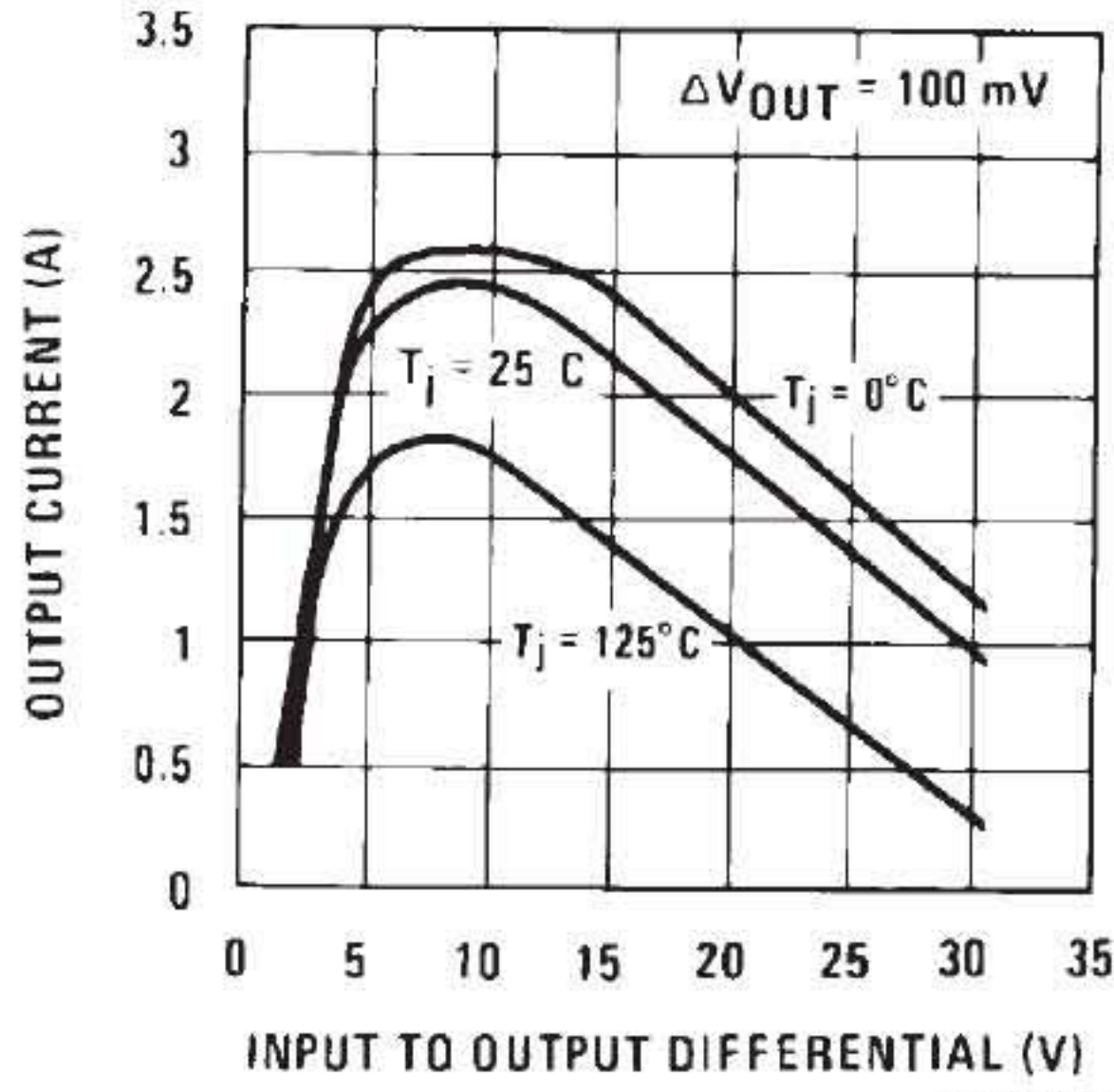

DS007746-7

Output Voltage (Normalized to 1V at $T_j = 25^\circ\text{C}$)

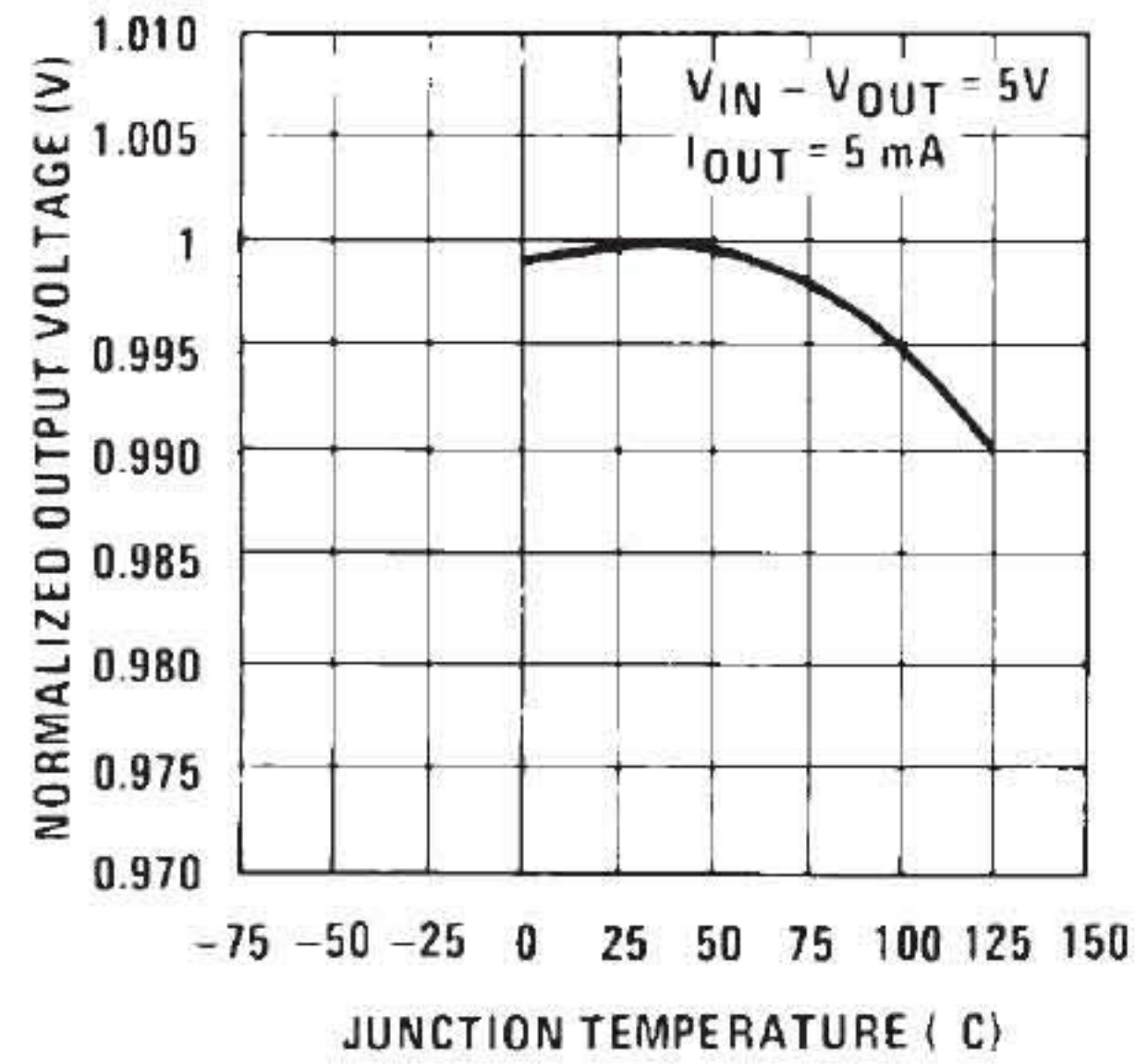

DS007746-8

Ripple Rejection

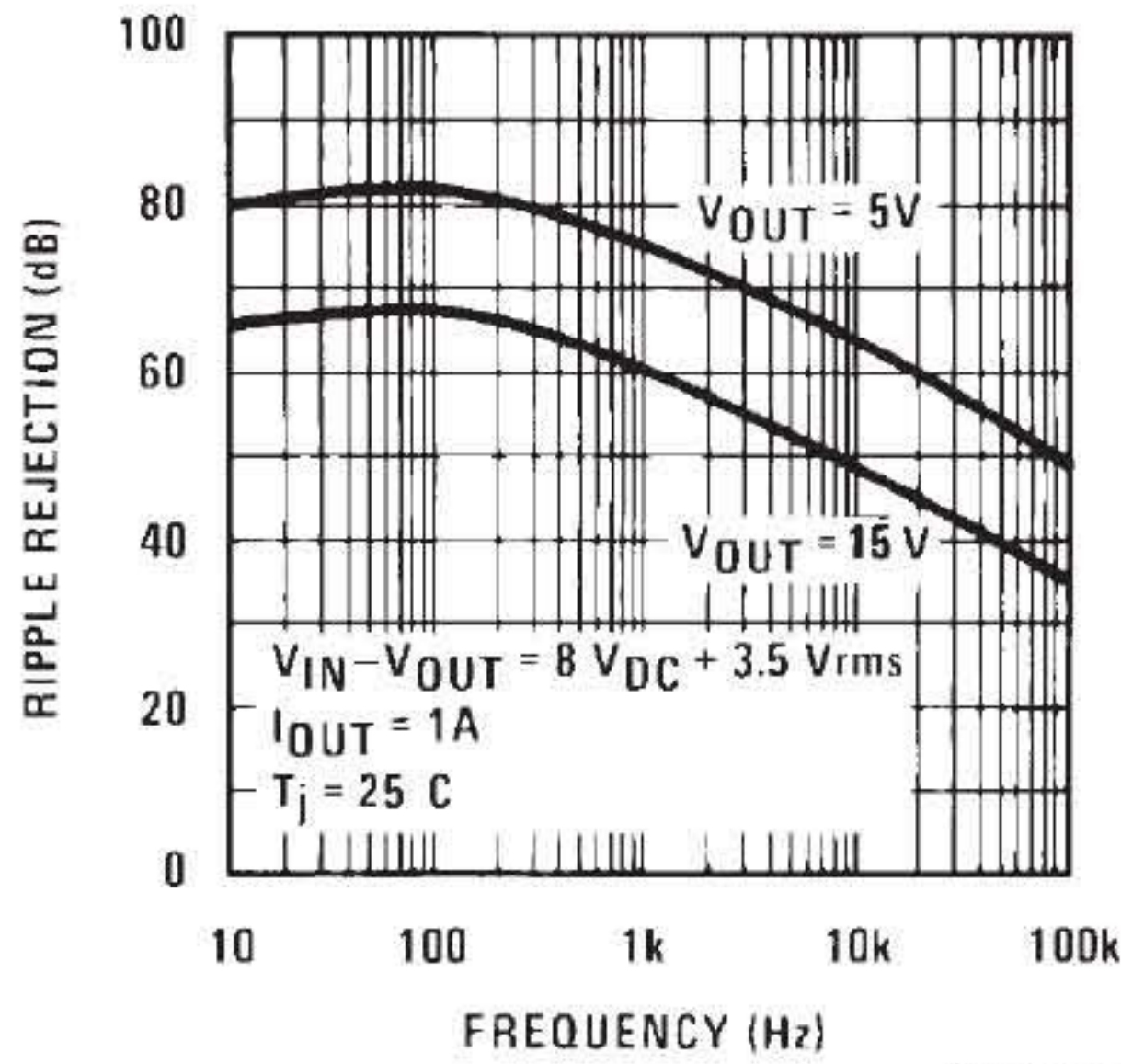

DS007746-9

Ripple Rejection

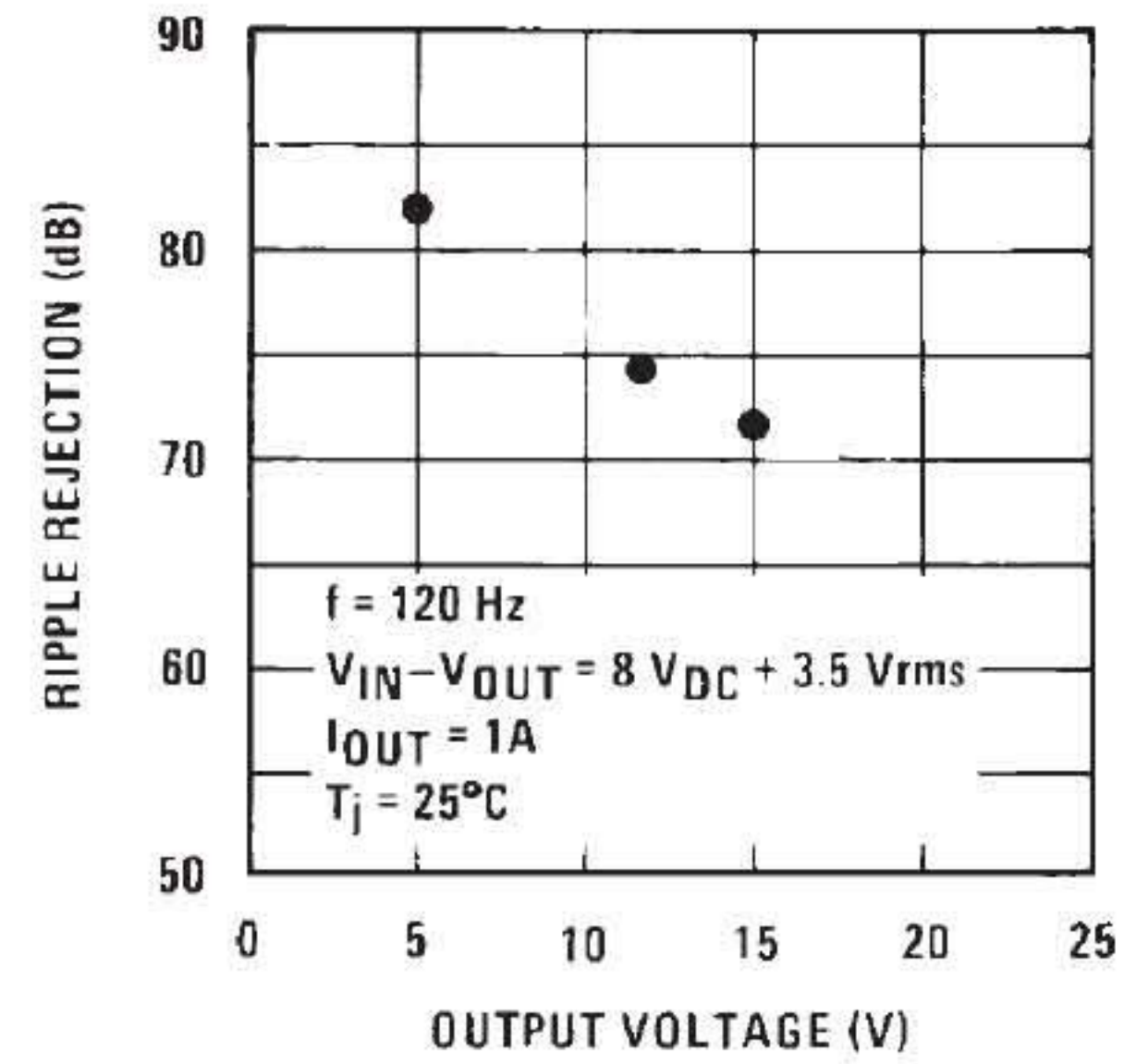

DS007746-10

ARTSCHIP

Typical Performance Characteristics (Continued)

Output Impedance

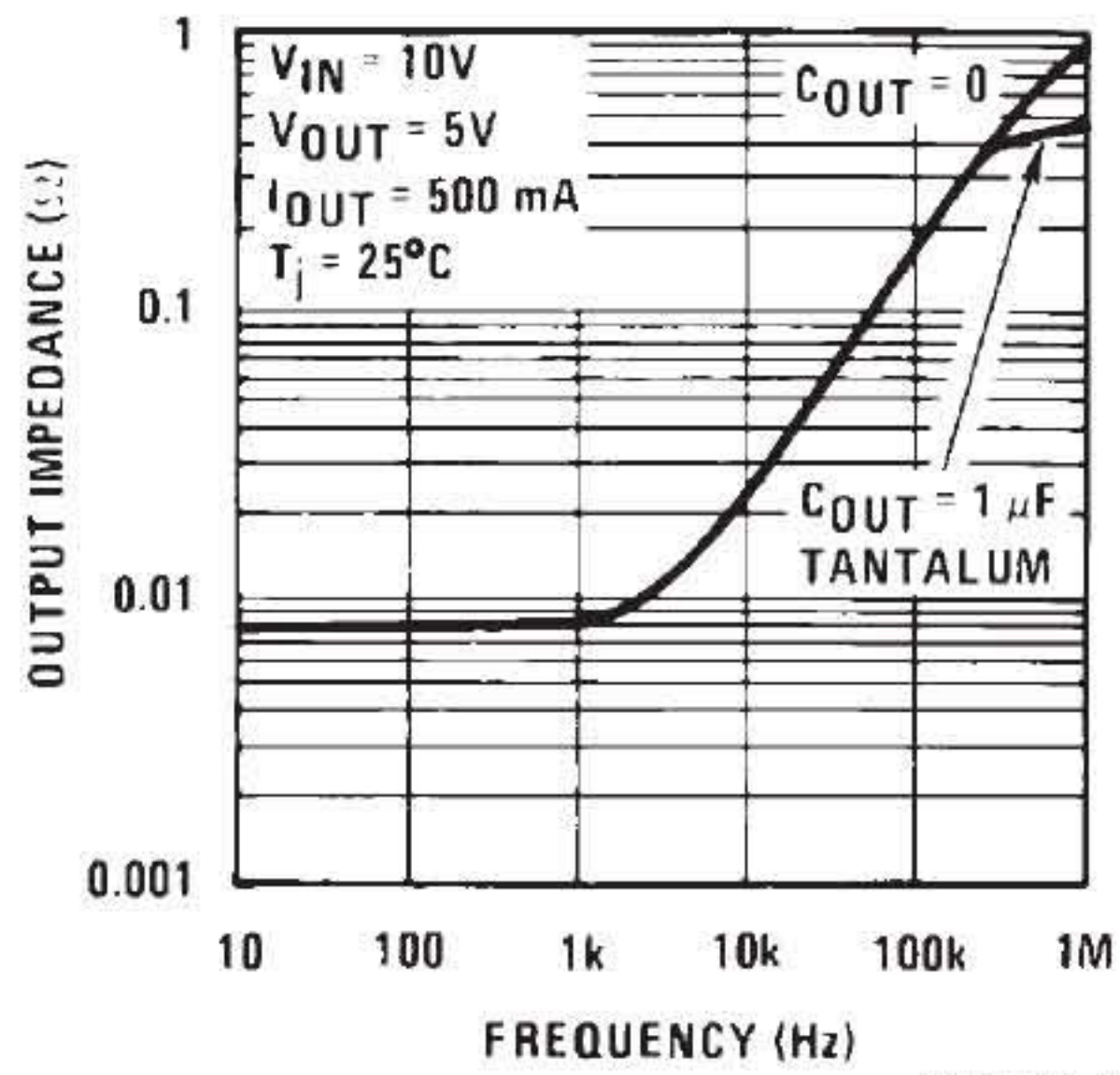

DS007746-11

Dropout Voltage

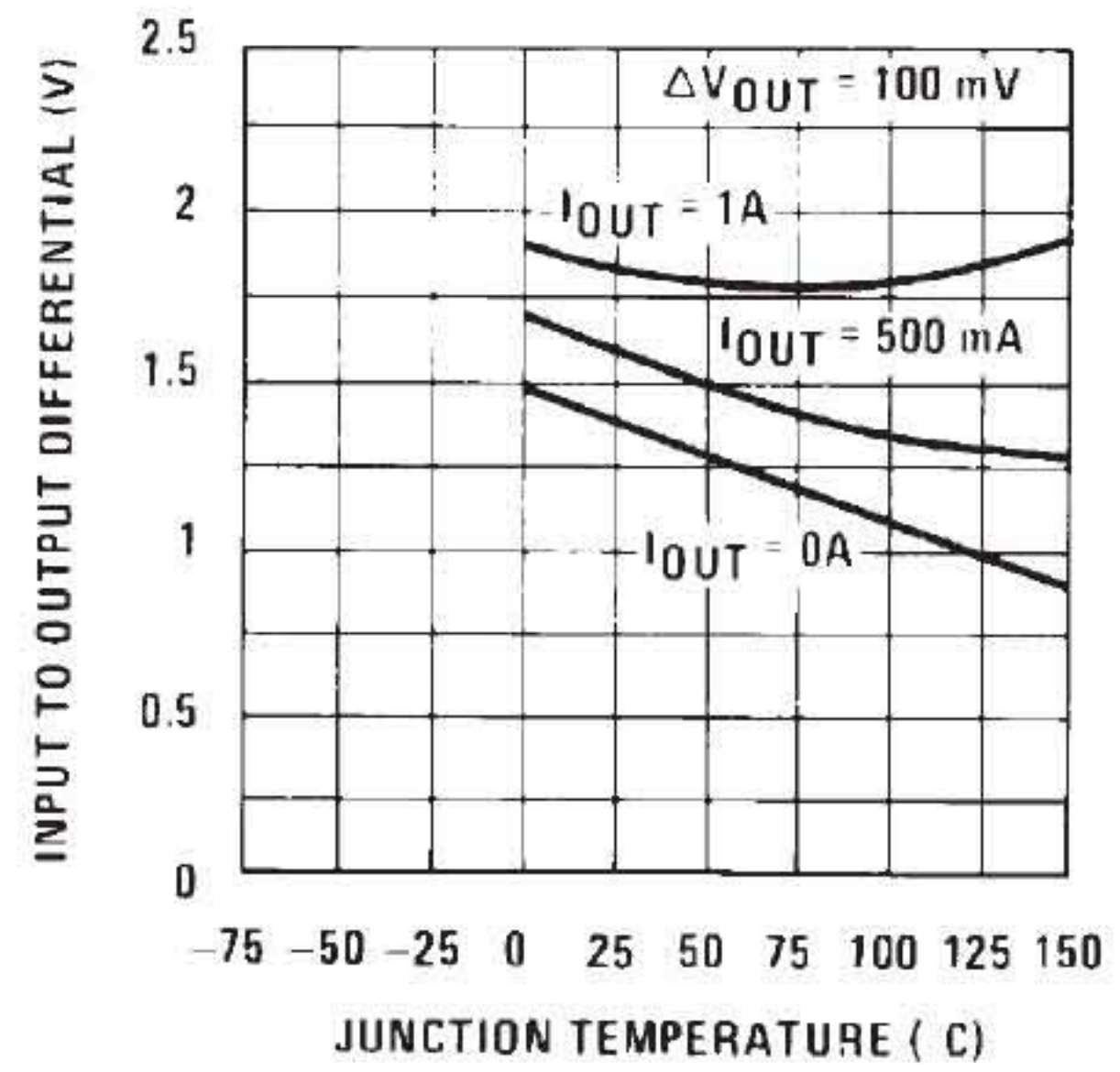

DS007746-12

Dropout Characteristics

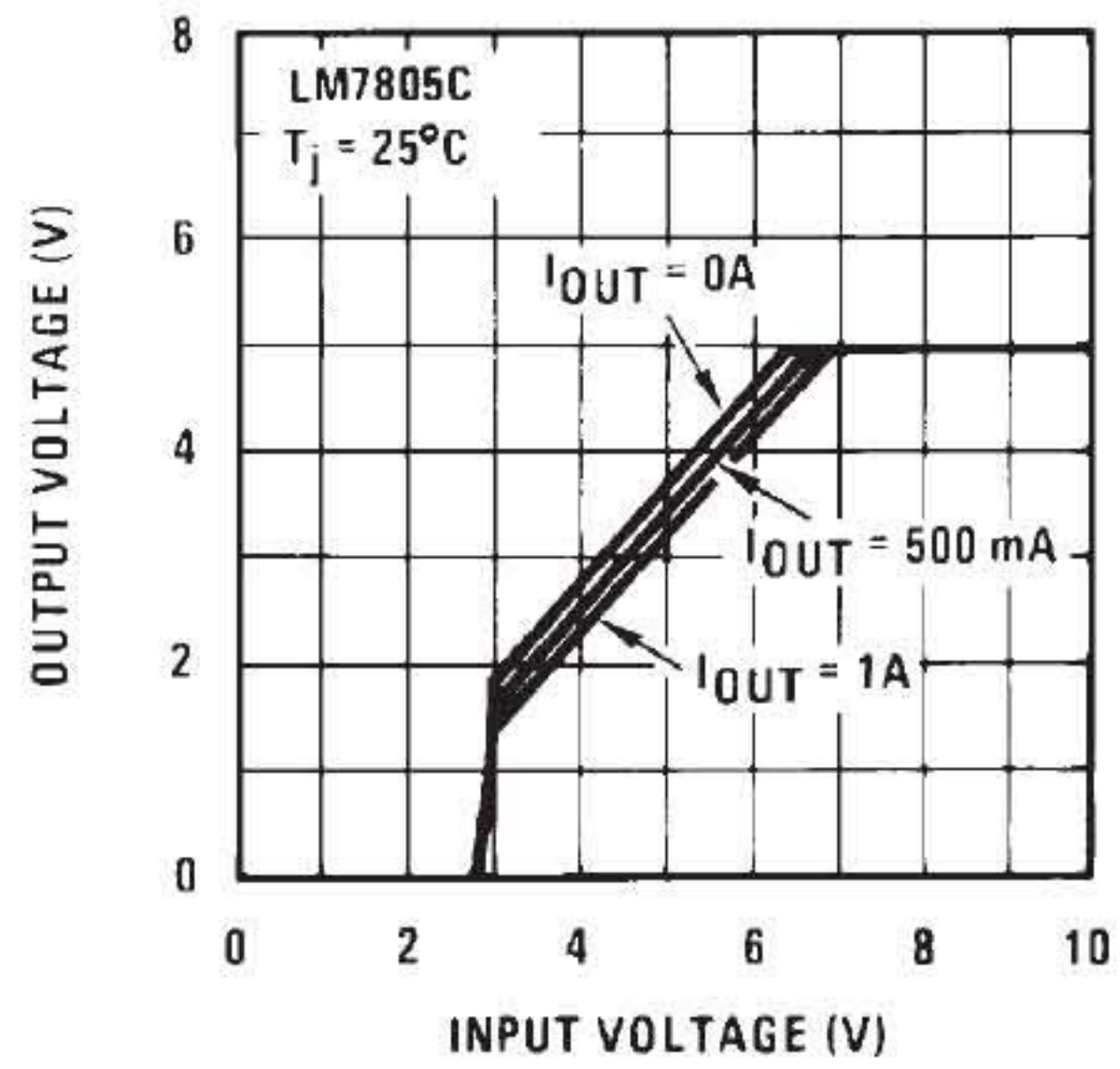

DS007746-13

Quiescent Current

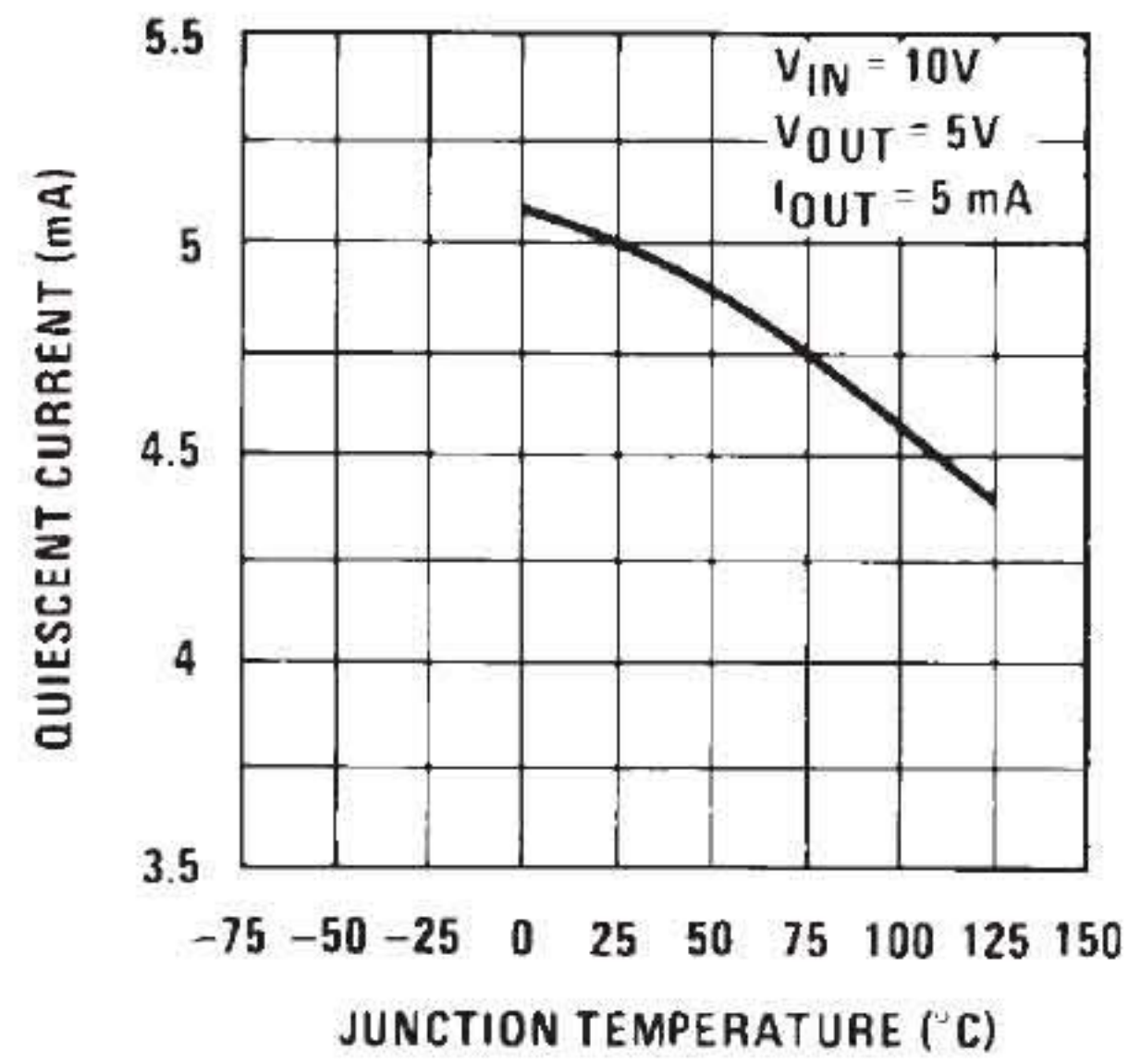

DS007746-14

Quiescent Current

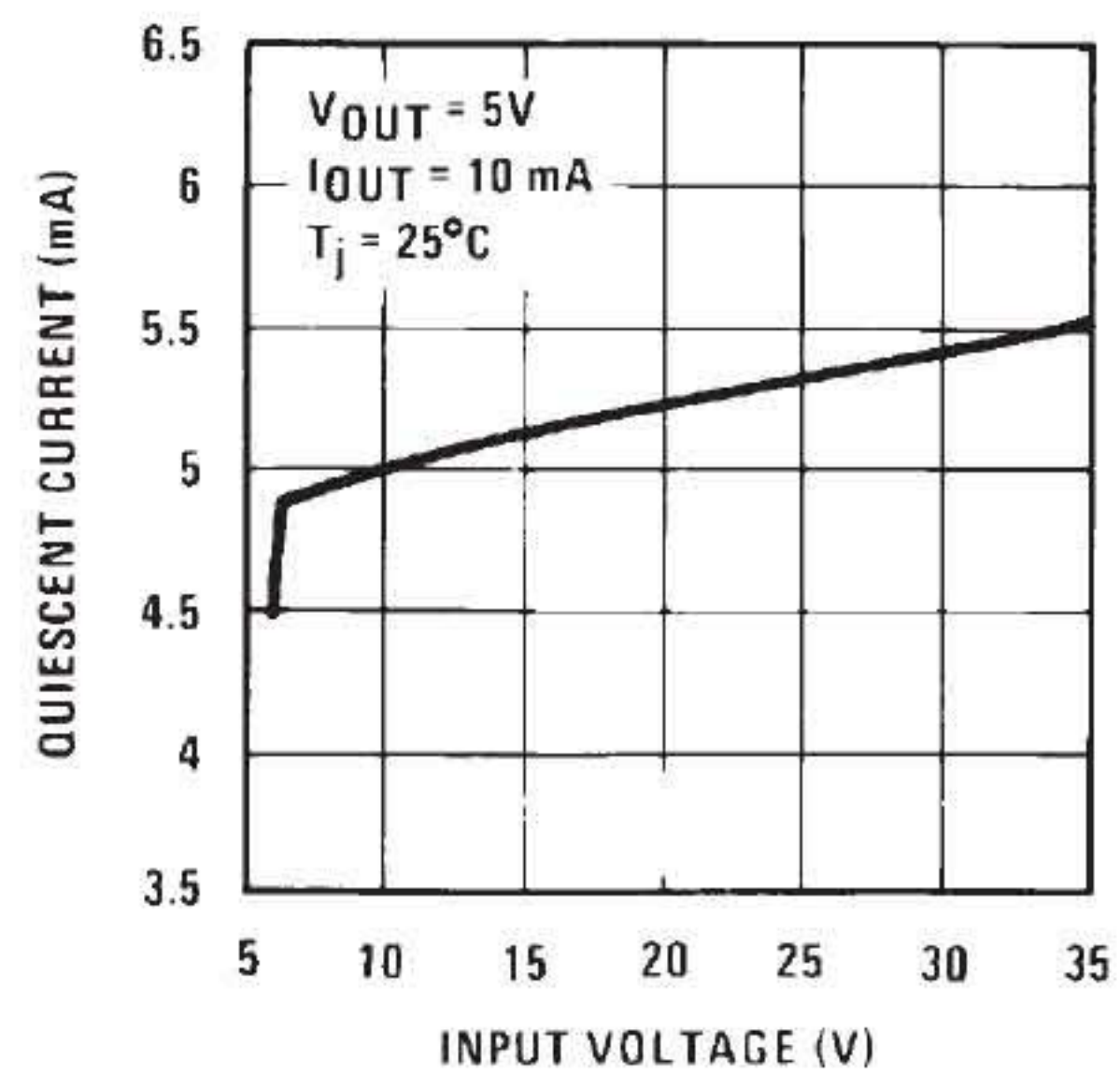

DS007746-15

Physical Dimensions inches (millimeters) unless otherwise noted

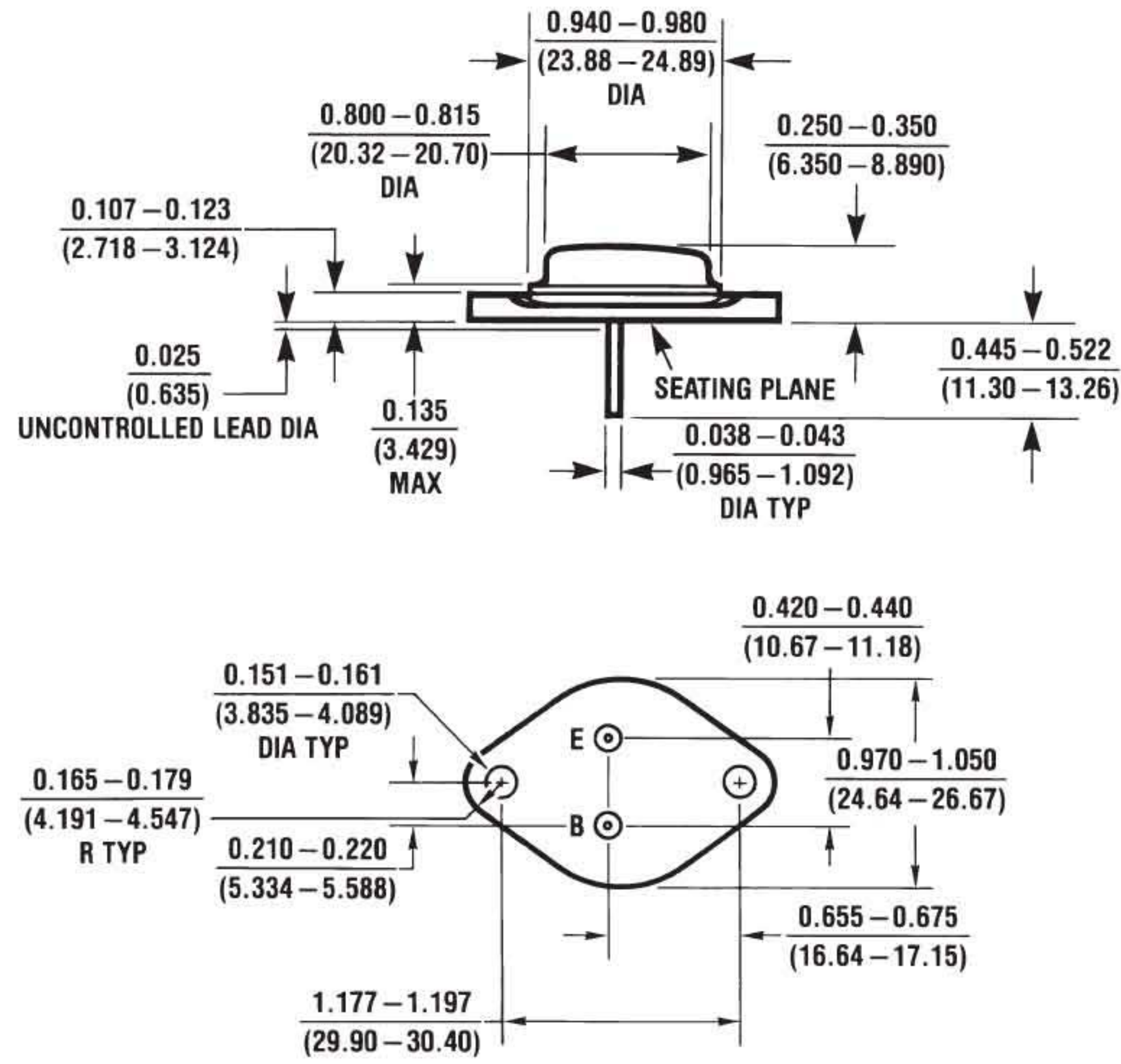

KC02A (REV C)

Aluminum Metal Can Package (KC)
Order Number LM7805CK, LM7812CK or LM7815CK

Physical Dimensions inches (millimeters) unless otherwise noted (Continued)

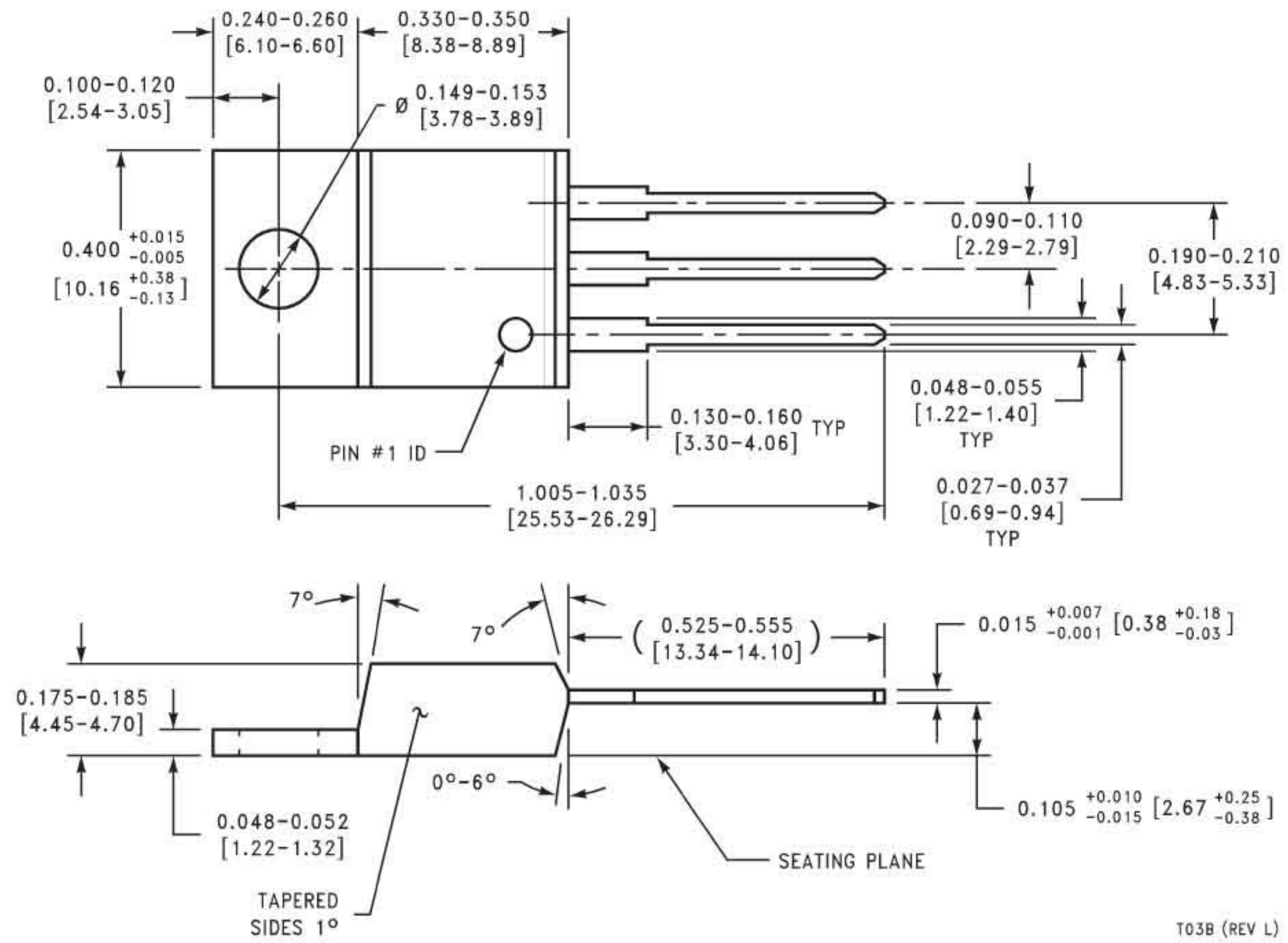

T03B (REV L)

TO-220 Package (T)
Order Number LM7805CT, LM7812CT or LM7815CT